

RoHS compliant

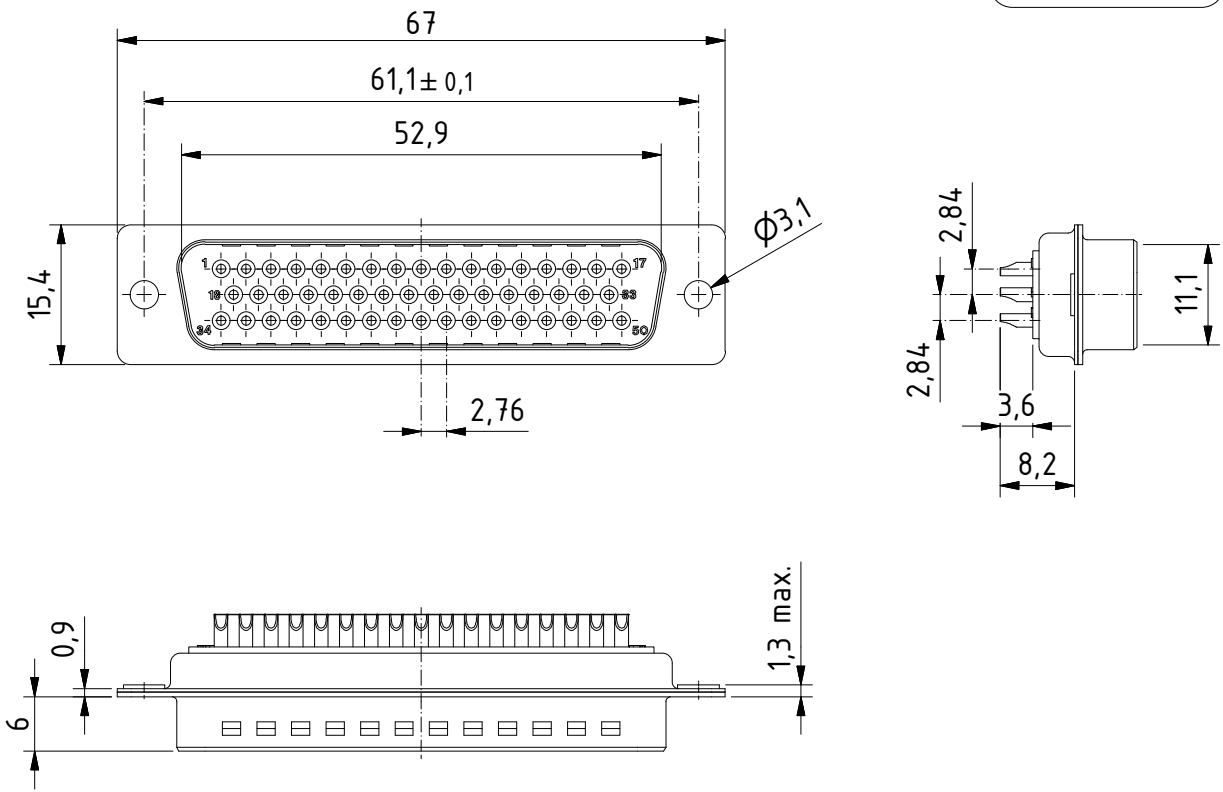

suitable for cable AWG 18

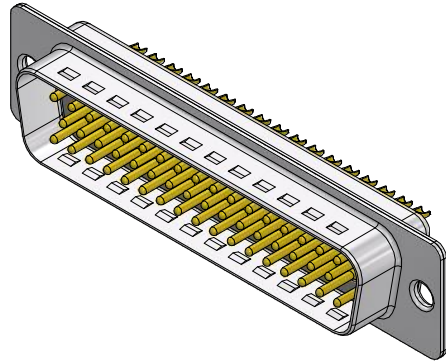

**MATERIALS**

- Insulator: Thermoplastic UL 94-V-0 white
- Contact: Copper alloy
- Contact finish: Quality class 2
- Shell: steel tin plated

**CHARAKTERISTICS**

- Working voltage: 125V
- Current rating: 5A
- Contact resistance: max. 10mΩ - DIN41652
- Insulation resistance: >5GΩ
- Temperature range: -55° to +125°C

<b>General tolerances</b> (Deltron standard)			
size in mm			
> 0.5	> 3	> 6	> 30
up to 3	up to 6	up to 30	up to 120
tolerances			
±0.1	±0.2	±0.2	±0.3

modification	Rev. a) 29.03.2010 mr	Rev.	Rev.	DE001232 part no.		
	Rev.	Rev.	Rev.			
DTS50PZ/2	1.2:1 scale	drawn	27.01.1998	mr		
		checked				
		approved				
 Industrie Neuhof 8c CH-3422 Kirchberg				K050019 a drawing no.		