

REV. 版本	ECN NO. 变更说明	DATE 日期
A	整理图画发行	17.05.11

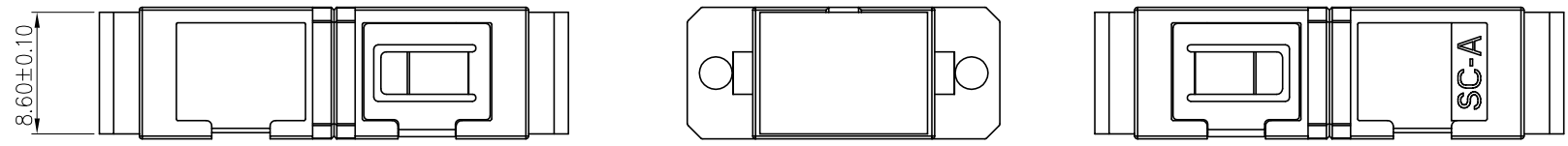
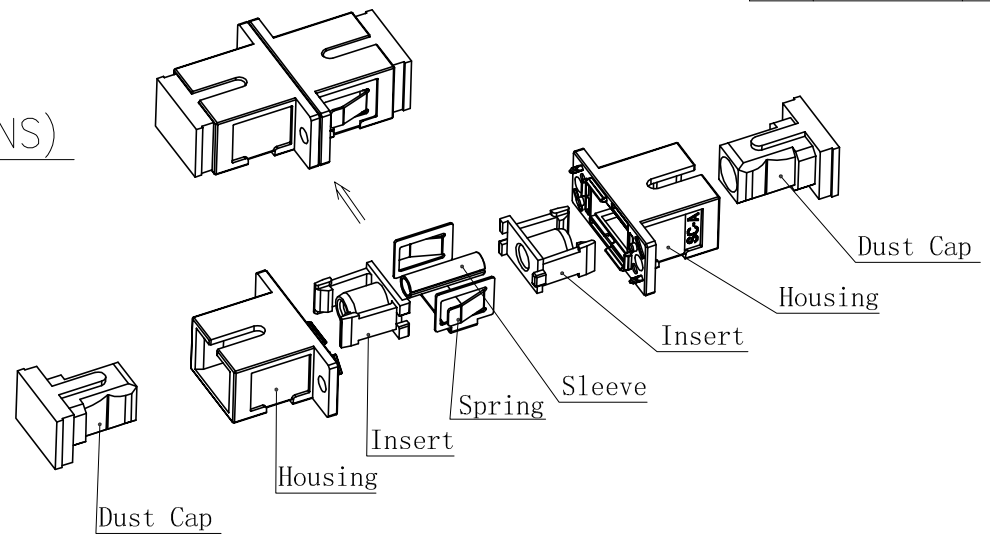
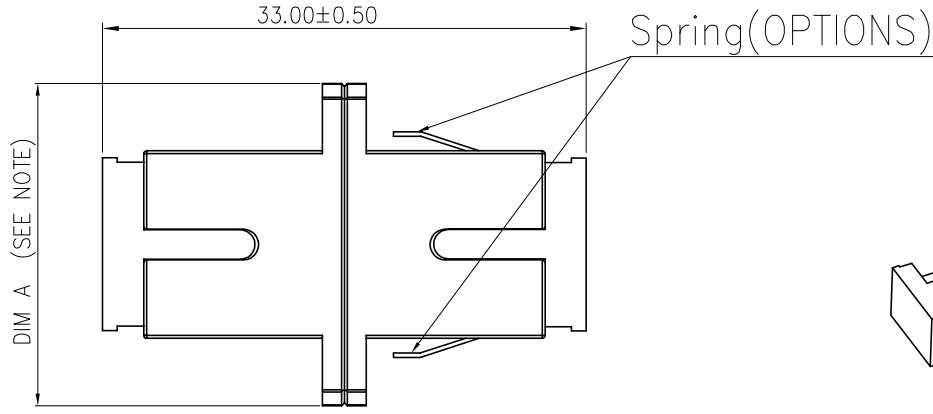

NOTE:

Features:

- Standards of IEC, EIA/TIA, Telcordia
- Insertion loss: <0.2dB
- Mechanism durability (500 cycles min) : <0.2dB
- Work temperature: -40°C~+85°C

No.	Part name	Qty	Material
5	Sleeve	1	ZrO2
4	Dust Cap	2	SEE TABLE 1
3	Spring	1	SEE TABLE 1
2	Insert	2	Plastic
1	Housing	2	Plastic

RoHS Compliant

<b>CZT</b> 温州意华接插件股份有限公司 WENZHOU YIHUA CONNECTOR CO., LTD				TOLERANCES 公差 .0 ± 0.30 .00 ± 0.25 .000 ± 0.15		Material: 材质 SEE NOTE Finish: 电镀 SEE NOTE		Designed: 设计 胡绍平 Checked: 审核 胡绍平		NAME: 名称 SC适配器 DWG NO: 图号 ESF150305		REV. 版本 A
第三视角 A4 SIZE	SCALE 比例 1:1	UNIT 单位 mm	CUSTOMER: 客户 N/A MODEL NO: 料号 N/A	ANGLES ± 0.5		SHEET 1 OF 2 第 1 页 共 2 页		Approved: 核准 蔡社民		PART NO: 料号 SEE TABLE 1		

REV. 版本	ECN NO. 变更说明	DATE 日期
------------	-----------------	------------

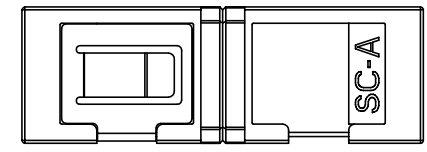
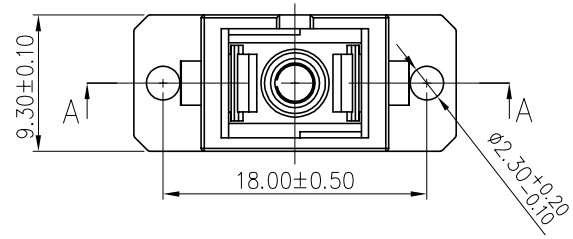
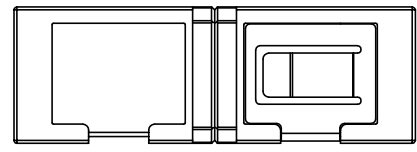
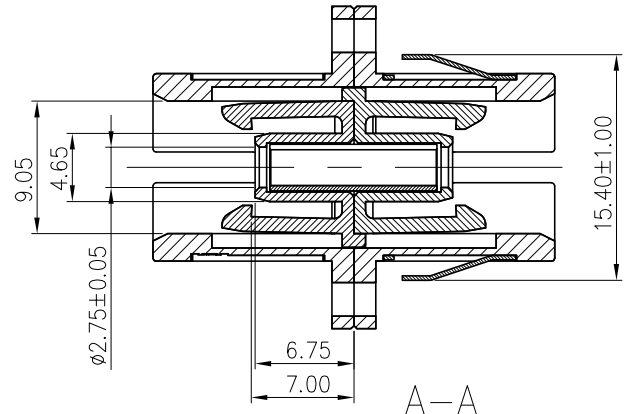
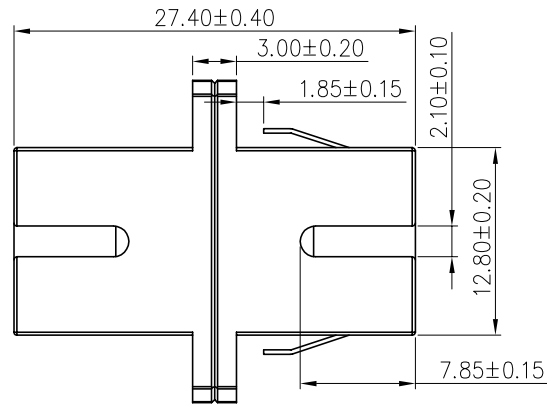

TABLE 1:

10790100W040	SC/PC ADAPTOR PBT BLACK CAP	Blue RAL5015	W/	10790300W031		SC/APC ADAPTOR PBT BLACK CAP	Green D0C520007	W/O
10790100W007	SC/PC ADAPTOR PBT BLACK CAP	Blue 2184C	W/	10790300W018		SC/APC ADAPTOR TPV BLACK CAP	Green 7737C	W/O
10790300W008	SC/APC ADAPTOR PBT BLACK CAP	Green 7737C	W/O	10790300W003		SC/APC ADAPTOR PVC BLACK CAP	Green 7737C	W/O
10790100Y002	SC/PC ADAPTOR PVC BLACK CAP	Blue 2184C	W/O	10790300W004		SC/APC ADAPTOR PBT BLACK CAP	Green 7737C	W/
10790300W022	SC/APC ADAPTOR PBT GREEN CAP	Green 7737C	W/	10790100W003	B869N-0000-001	SC/PC ADAPTOR PVC BLACK CAP	Blue 2184C	W/O
10790300W019	SC/APC ADAPTOR TPV BLACK CAP	Green 7737C	W/	10790100W002	B869N-0000-0028	SC/PC ADAPTOR PVC BLACK CAP	Blue 2184C	W/
PART NUMBER	DESCRIPTION	Housing&Insert color	Spring	PART NUMBER	PART NUMBER(OLD)	DESCRIPTION	Housing&Insert color	Spring

 第三视角 A4 SIZE	<b>CZT</b> ® 温州意华接插件股份有限公司 WENZHOU YIHUA CONNECTOR CO., LTD		TOLERANCES 公差 .0 ± 0.30 .00 ± 0.25 .000 ± 0.15 ANGLES ± 0.5	Material: 材质 SEE NOTE	Designed: 设计 胡绍平	NAME: 名称 SC适配器	REV. 版本 A
	SCALE 比例 1:1	UNIT 单位 mm	CUSTOMER: 客户 N/A	Finish: 电镀 SEE NOTE	Checked: 审核 胡绍平	DWG NO: 图号 ESF150305	
	SHEET 2 OF 2 第 2 页 共 2 页		MODEL NO: 料号 N/A	Approved: 核准 蔡社民	PART NO: 料号 SEE TABLE 1		