

SMD Crystal Oscillator 2.0 × 1.6 mm

Feature

- Typical 2.05 x 1.65 x 0.75 mm SMD package.
- Tight symmetry (45 to 55%) available.
- Operation voltage: 1.8V, 2.5V, 3.3V
- Tri-state enable/disable
- RoHS compliant/Pb-free

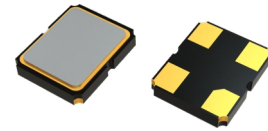

Electrical Specifications

Parameter	3.3V		2.5V		1.8V		Unit	
	Min.	Max.	Min.	Max.	Min.	Max.		
Supply Voltage Variation	2.97	3.63	2.25	2.75	1.62	1.98	V	
Frequency Range	1.5	50	1.5	50	1.5	50	MHz	
Standard Frequency	24,26,32,40						MHz	
Supply Current	-	15	-	10	-	7	mA	
Duty Cycle	45	55	45	55	45	55	%	
Transition Time : Rise/Fall Time	1.5 MHz ≡ FO<20MHz	-	4	-	4	-	5	nSec
	20 MHz ≡ FO<50MHz	-	3	-	3	-	4	
Output Level (CMOS)	Output High(Logic"1")	2.97		2.25		1.62		V
	Output Low(Logic"0")	0.33		0.25		0.18		
Start Time	-	2	-	2	-	2	mSec	
Tri-State (Input to Pin 1)	Enable(High Voltage or floating)	2.31	-	1.75	-	1.26	-	V
	Disable(Low Voltage or GND)	-	0.99	-	0.75	-	0.54	
Period Jitter (Pk-Pk)	-	40	-	40	-	40	pSec	
RMS Phase Jitter (integrated 12KHz to 20MHz)	-	1	-	1	-	1	pSec	
Standby Current	-	10	-	10	-	10	µA	
Aging (@25 1st year)	-	±3	-	±3	-	±3	ppm	
Storage Temp. Range	-55	125	-55	125	-55	125	°C	

Standard frequencies are frequencies which the crystal has been designed and does not imply a stock position
 .+ Transition times are measured between 10% and 90% of VDD, with an output load of 15pF.

Dimension(mm)

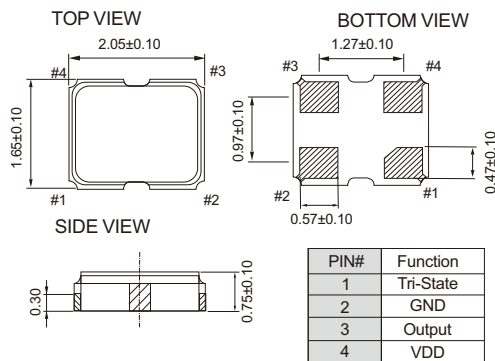

Solder Pad Layout(mm)

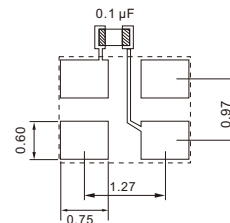

To ensure optimal oscillator performance, place a by-pass capacitor of 0.1 µF as close to the part as possible between Vdd and GND pads.

FREQ. STABILITY vs. TEMP. RANGE

Temp. (°C) \ ppm	±20	±25	±50
-10 ~ +60	o	o	o
-20 ~ +70	△	o	o
-40 ~ +85	X	o	o
-40 ~ +125	X	X	o

o: Available △: Conditional X: Not available
 Inclusive of calibration @ 25 °C, operating temperature range, input voltage variation, load variation, aging (1st year), shock, and vibration