

ACTIVE HIGH PRECISION AMPLIFIER

—Detection type TExxxxN series

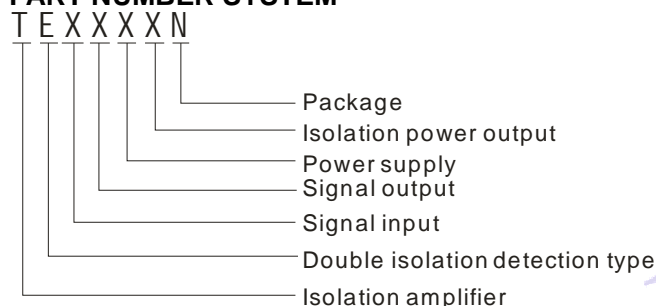

PART NUMBER SYSTEM



FEATURES

- I 2-port isolation (input and output)
- I High accuracy (0.1% F.S.)
- I High linearity (0.1% F.S.)
- I High isolation voltage(2KVAC/60s)
- I Low ripple & noise: ≤30mVpp (20MHz)
- I Extremely low temperature drift (-25~+71°C:≤35PPM/°C)
- I Small size: DIP18 (26*9.5*12.5mm)
- I ESD protection (IEC/EN61000-4-2 contact ±4KV perf. Criteria B)
- I With load ability: ≥2KΩ (@MAX SIGNAL OUTPUT @10V)

GENERAL DESCRIPTION

The TExxxxN series is with preceding voltage/current signal input and backward voltage signal output, and with an inner high efficiency isolated micro-power source. It can provide isolation power to peripheral circuit at the same time of providing power to internal signal processing circuit.

Adopting electromagnetism isolation technology, therefore compared with photo-coupler isolation, it has higher accuracy and lower temperature drift. This module is two-port isolation (input and output). There are external functions for the series as zeros and full adjustment, convenient for customer to design and adjust.

SELECTION GUIDE

Model	Power Supply	Input	Output	Isolation Power Output	Channels
TE5534N	24V	0~10V	0~10V	15V	1
TE5544N	15V	0~10V	0~10V	15V	1
TE5554N	12V	0~10V	0~10V	15V	1
TE5634N	24V	0~10V	0~5V	15V	1
TE6634N	24V	0~5V	0~5V	15V	1
TE6644N	15V	0~5V	0~5V	15V	1
TE6654N	12V	0~5V	0~5V	15V	1
TE6664N	5V	0~5V	0~5V	15V	1
TE1533N	24V	4~20mA	0~10V	24V	1
TE1530N	24V	4~20mA	0~10V	NONE	1
TE1550N	12V	4~20mA	0~10V	NONE	1
TE1633N	24V	4~20mA	0~5V	24V	1
TE1630N	24V	4~20mA	0~5V	NONE	1
TE1660N	5V	4~20mA	0~5V	NONE	1

ELECTRICAL SPECIFICATIONS

Power Supply	Power Supply	(Nominal power supply)±5%
	Input Power	≤1.0W(No isolation power output) ≤1.5W(No isolation power output)
	Power Protection	Reverse protection(The product of 5V power input is without this function)
Isolation Power Output	Output Voltage	(Nominal)±10%
	Output Current	≤25mA
Input	Input Signal	Refer to the above selection guide

	Input Impedance	$\geq 10\text{M}\Omega$ (Max. voltage signal input)	$\leq 250\text{mV}$ (Max. current signal input)
	Over-load	$\leq 30\text{V}$ (Voltage signal input)	$\leq 50\text{mA}$ (Current signal input)
Output	Output Signal	Refer to the above selection guide	
	With Load Ability	$\geq 2\text{k}\Omega$	
	Ripple & Noise	$\leq 30\text{mVpp}$ (20MHz bandwidth)	

TRANSMISSION SPECIFICATIONS

Zero Offset	0.1%F.S.		
Accuracy	0.1%F.S.		
Temperature Drift	35PPM/°C (-25~+71°C); 50PPM/°C (-40~+85°C)		
Adjustable Function	Full Degree Regulation	Can be adjusted within $\pm 5\%$ output signal range	
	Zero Regulation	Can be adjusted within $\pm 5\%$ output signal range	
Frequency Response	Bandwidth	$\geq 2\text{KHz}$	
	Response Time	$\leq 1\text{mS}$	

ISOLATION SPECIFICATIONS

Electrical Isolation	Power input and the signal output are on the common ground. Power output and the signal input are on the common ground. Isolated between power input and the signal output or power input and power distribution output.		
Isolation voltage	2.0KVAC (Tested for 1minute, leakage current < 1mA, humidity < 70%)		
Insulation Resistance	100MΩ (500VDC)		

EMC SPECIFICATIONS

EMI	CE	CISPR22/EN55022	CLASS A (Recommended Circuit Refer to Figure 1)	
	RE	CISPR22/EN55022	CLASS A	
EMS	ESD	IEC/EN61000-4-2	Contact $\pm 4\text{KV}$	perf. Criteria B
	RS	IEC/EN61000-4-3	10V/m	perf. Criteria A
	EFT	IEC/EN61000-4-4	Power port $\pm 2\text{KV}$ (Recommended Circuit Refer to Figure 1)	perf. Criteria B
	Surge	IEC/EN61000-4-5	Power port $\pm 1\text{KV}/\pm 2\text{KV}$ (Recommended Circuit Refer to Figure 1)	perf. Criteria B
	CS	IEC/EN61000-4-6	3 Vr.m.s	perf. Criteria A

OTHER SPECIFICATIONS

Ambient Temperature	Operating temperature:-	-40~+85°C
	Transport and storage temperature:-	-50~+105°C
Package	DIP18	
Weight	8g (typ.)	
Application Environment	Dust-free, fierce shocking, impulsion and corrosive gas	

APPLICATION CIRCUIT DIAGRAM

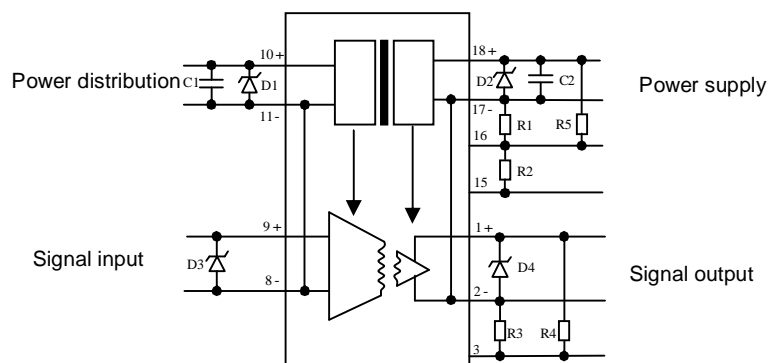

(Figure 1)

C1	100uF/35V
C2	100uF/35V
R1	Negative zero adjustment resistance ^①
R2	Positive zero adjustment resistance ^①
R3	Positive gain adjustment resistance ^①
R4	Negative gain adjustment resistance ^①
R5	Positive zero adjustment resistance ^{①②}
D1	SMCJ30A
D2	SMCJ28A
D3	SMBJ15A
D4	SMBJ15A

Note: ① Adjustment resistance is chosen according to the requirement.
② R5 is only used for regulation of 24V input product.

APPLICATION

1. Schematic diagram

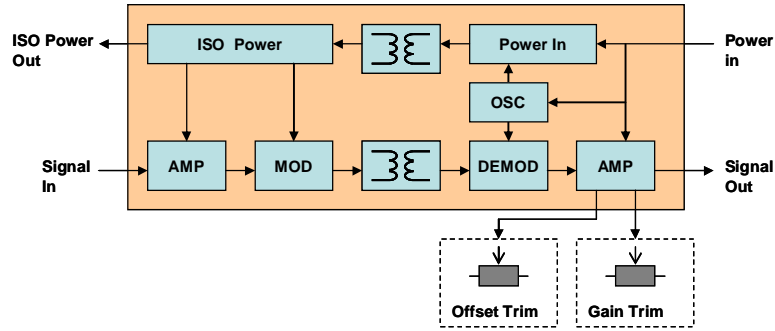

2. Typical application—Multi-channel signal acquisition

Application circuit for typical multi-channel signal acquisition is as below:

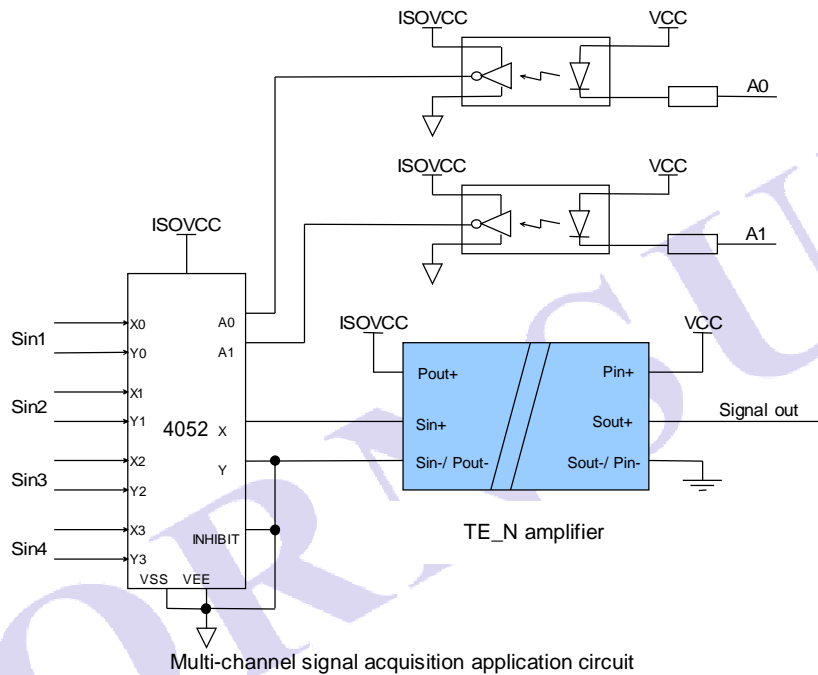

Multi-channel signal acquisition application circuit

Function

In the figure, Sin1~Sin4 are external input signal, A0~A1 are strobe signal, and signal out is an external input signal of control system to accept. The optocoupler in the circuit implements the isolated transmission of strobe signals. Amplifier of TE-N series implements the isolated transmission of signals and isolated power supplement. The multi-channel strobe chips 4052 implements selective transmission of multiplex signals.

Working principle

When the circuit works, the control system sends out the strobe signal A0~A1. Optical coupling isolation circuit transfers strobe signal to multi-channel strobe chips 4052, and control the chip to correspond channel. External signal Sin1~Sin4 input to multi-channel strobe chips 4052. After a chip strobe, strobe signal transfers to the signal input of TE _ N transmitter. TE _ N transmitter output the isolated input signal to control system, thus it implements the control system and the external signal isolation circuit. Input power of TE_N transmitter and the input Vcc of strobe signal transmission circuit are provided by control system. After strobe signal is isolated, transmission circuit power and multi-channel strobe chips 4052 power supply ISOVCC are provided by power distribution output Pout+.

3. Typical application —Isolated transmission for electrical signals

Typical application of isolated transmission for electrical signals is below.

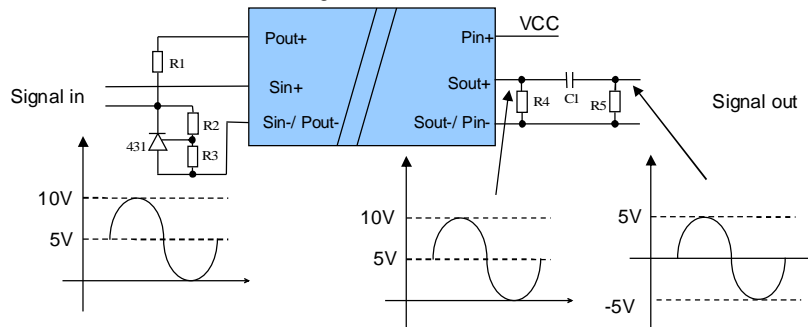

Isolated transmission for electrical signals application

Function

In the figure, Signal in is detected electrical signals, Signal out is electrical signals for control system of isolation transmission. VCC is isolated power supply provided from control system. Typical power signal is positive and negative sine wave signal. 431 R1 R2 and R3 is voltage stabilizing circuit in the circuit, and they can achieve zero adjustment of the input signal. Amplifier of TE_N series achieve signal transmission function and power supply function of voltage stabilizing circuit. R4,R5,C1 achieve DC output signal filtering functions.

Working principle

Supposing detected signal is 5V sine wave signal. When the input signal is passed through stabilizing circuit which is composed of 431,R1,R2 and R3, input signal of TE_N transmitter become 0~10V sine wave signal. If the amplifier is the one which has 0~10V input and 0~10V output, TE_N transmitter output would be output 0~10 v sine wave signal at this time. After passed through filter circuit which is composed of R4,R5 and C1, the DC component of 0~10V sine wave signal is filtered, and the output only have $\pm 5V$ sine wave signal.

Parameter

In the application, typical values of R1, R2 and R3 are 10K Ω , and reference Voltage of 413 is 2.5V. Component regulated voltage is 5V. Voltage accuracy can achieve a variety of application requirements of high precision according to the resistance tolerance precision. Typical application range of R4 is 2K Ω ~5K Ω . Because signal output voltage is positive and negative, there will be a transmitter output signal current return-irrigation phenomenon when the voltage signal output is negative.R4 should choose a smaller value in order to reduce the influence of the return-irrigation current. C1 should be chosen low internal resistance capacitance. Normally ceramic capacitor with volume more than 10uF will be suitable. Because C1 achieves the function of getting through AC and preventing DC. Large capacitance resistance and small capacitance value can make AC signal distorted. The recommended value of R5 should be more than 100K Ω , and implements a DC signal to zero in the circuit. The increase of value of R5 can make the time of DC signal to zero longer, and make the startup time longer. If load in circuit is too small, then the load for AC will be increased, so that AC signal will be distorted.

Notice

Because the transmitter of TE_N series can not input negative voltage signal, it need to pay attention to narrow signal voltage amplitude and have the necessary margin in the design. It can guarantee the normal work of the circuit and reduce the risk of signal distortion.

4.Application—Zero and full adjustment function

Zero and full adjustment recommended setting circuit is as shown

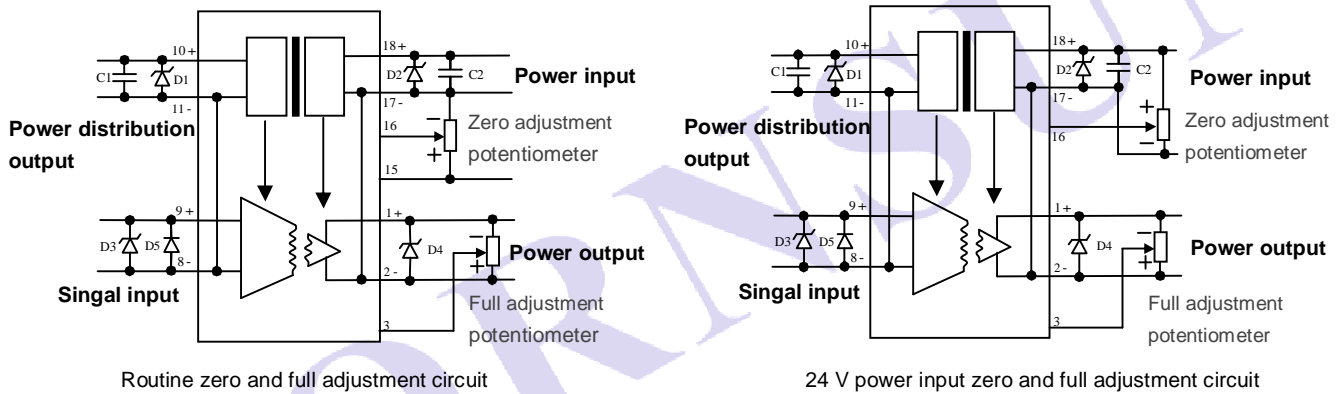

Function

Zero adjustment function by setting up adjustment resistor at the zero point can change the zero signal transmission, which makes the output signal overall migration. Full adjustment function is also called the gain adjustment function, and it can change the ratio of signal transmission through the set up corresponding adjust resistance at the full adjustment, and the isolation transmission proportion of input and output signal value would be changed.

Usage

Adding and reducing negative zero resistance can reduce the zero of signal output. Adding and reducing positive zero resistance can increase the zero of signal output. Adding and reducing negative full adjustable resistance can reduce the ratio of signal transmission, Adding and reducing negative full adjustable resistance can increase the ratio of signal transmission. You can use potentiometer to adjust the output signal of zero and full in practical application. As shown in the figure, the terminal of full or zero adjustment is connected to the sliding of potentiometer, and the both ends of potentiometer is to the zero or full reference of positive and negative regulating reference. Sliding potentiometer to adjust signal full or changing the ratio of rise and fall can also adjust zero and full of the output signal.

As shown in the figure, zero positive reference adjusting is different between 24V input product and other power input products, so the zero adjustment circuit is also different. Adjusting the potentiometer to positive can increase zero or full of the corresponding signal. Adjusting the potentiometer to negative can reduce zero or full of the corresponding signal. The maximum recommended range of potentiometer is 10K Ω ~1M Ω , detail resistance selection according to the adjustment accuracy. Choose larger resistance potentiometer for high precision fine-tuning. Choose smaller resistance potentiometer for a wide range of rough adjustment.

Notice

The accuracy of transmitter of TE_N series is already 0.1%FS during production and before shipment, using the function of zero and full adjustment will affect original accuracy. Due to the effect on temperature drift of external adjustment resistor and the stability of the potentiometer, temperature drift of product will be changed, too.

The 1:1 ratio for positive resistance and negative resistance of full adjustment potentiometer is desired full adjustment. For the zero adjustment potentiometer, the ratio between positive resistance and negative resistance, which makes the zero point of different products predetermined Zero point is diverse. Please set the value of potentiometer according to actual situation.

NOTICE

1. Please read the user manual carefully before using. If any question please contact our FAE.
2. Please do not use this product in hazardous area.
3. The power supply of this product should be 24VDC power source. It is forbidden to use 220VAC power supply.
4. To avoid invalid explosion protection function, or any failure, disassembling this product is forbidden.

AFTER-SALES SERVICE

1. Products are carefully inspected and quality controlled during production and before shipment. If they operated abnormally or there was anything wrong, please contact our agent from which you purchased or MORNSUN FAE as soon as possible.
2. MORNSUN warranty our product for 3 years from manufacturing date. During this period, MORNSUN will repair or replace the product if product was found to have manufacturing defect.

APPLICATION CIRCUIT

Please check " A APPLICATION GUIDE TO ISOLATION TRANSMITTER"

DIMENSIONS, RECOMMENDED FOOTPRINT & PACKAGING

MECHANICAL DIMENSIONS

Front View
 Dimensions: 12.50 [0.492], 0.50 [0.020], 4.10 [0.161], 2.54 [0.100], 10.16 [0.400], 20.32 [0.800]

Bottom View
 Dimensions: 26.00 [1.024], 5.08±0.5 [0.200±0.020], 9.50 [0.374], 0.30 [0.012], 0.50 [0.020], 1.75±0.5 [0.069±0.020]

PIN CONNECTION					
1	Sout+	Signal output(+)	11	Pout-	Distribution output(-)
2	Sout-	Signal output(-)	15	ZR	Zero auxiliary regulation*
3	SG	Gain regulation	16	SZ	Zero regulation
8	Sin-	Singnal input(-)	17	Pin-	Power supply(-)
9	Sin+	Singnal input(+)	18	Pin+	Power supply(+)
10	Pout+	Distribution output(+)	* Note:the power supply of 24V without 15 Pin		

Note:
 Unit :mm[inch]
 Pin section tolerances :±0.1mm[±0.004inch]
 General tolerances:±0.25mm[±0.010inch]

THIRD ANGLE PROJECTION

RECOMMENDED FOOTPRINT DETAILS

Note : Grid 2.54*2.54mm

TUBE PACKAGING DIMENSIONS

Note:
 Unit :mm[inch]
 General tolerances:±0.50mm[±0.020inch]
 L=530mm[20.866inch] Tube Quantity:19 pcs
 L=220mm[8.661inch] Tube Quantity:7 pcs
 Inner carton(S): L*W*H=255*170*80 mm;
 Outer carton(S): L*W*H=375*280*270mm, 6 inner cartons(S);
 Inner carton(L): L*W*H=580*200*100mm;
 Outer carton(L): L*W*H=600*215*220mm, 2 inner cartons(L);
 Outer carton(L): L*W*H=600*215*325mm, 3 inner cartons(L);

Note:

1. All specifications measured at Ta=25°C, humidity<75%, nominal input voltage and rated output load unless otherwise specified.
2. In this datasheet, all the test setup and methods are based on our corporate standards.
3. All characteristics are for listed models, and non-standard models may perform differently. Please contact our technical support for more details.
4. Contact us for your specific requirement.
5. Specifications of this product are subject to changes without prior notice.

MORNSUN Science & Technology Co.,Ltd.

Address: No. 5, Kehui St. 1, Kehui development center, Science Ave., Guangzhou Science City, Luogang district, Guangzhou,P.R.China.

Tel: 86-20-38601850

Fax:86-20-38601272

E-mail: info@mornsun.cn

[Http://www.mornsun-power.com](http://www.mornsun-power.com)